

Bread slicers for professionals

PICOMATIC ONE

- ✔ Small footprint
- ✔ Can be used on a counter-top or on a base
- ✔ Automatic slicing cycle, simple to use and optimizes time management
- ✔ Ergonomic front loading design
- ✔ Intelligent Slicing Concept
- ✔ 5 years parts / 1 year labor warranty
- ✔ Up to 17" loaf

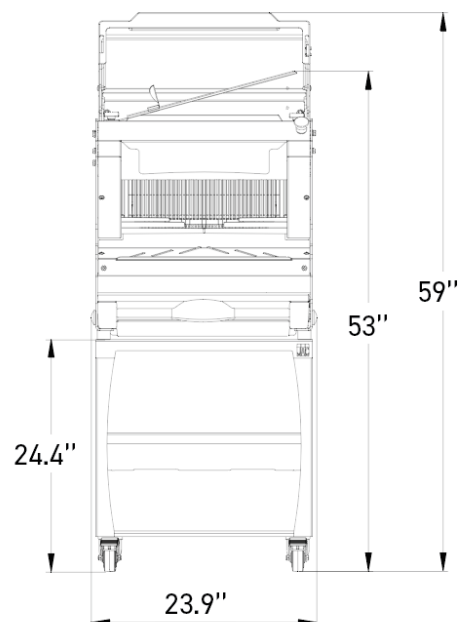
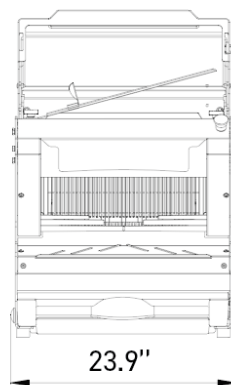
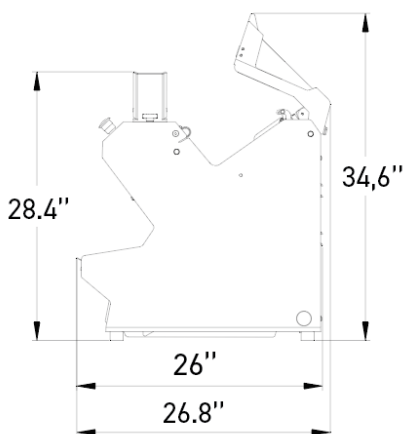

SPECIFICATIONS

Max. loaf dimensions in in (L x W x H)	17.3" x 11.8" x 7"
Rear safety cover	•
Motor power in kW	0.49
Type of motor	1ph/120V/60Hz/7.3A
Plug configuration	NEMA 5-15P
Net weight in lbs	231

TECHNICAL SPECIFICATIONS

Slice thickness options (in mm)	3/8" (10mm), 7/16" (11mm), 1/2" (13mm), 5/8" (16mm), 3/4" (19mm) (Extra cost), 7/8" (22mm) (Extra cost), 1" (25mm) (Extra cost), 1 1/4" (31mm) (Extra cost), Special slice thickness (Extra cost)
---------------------------------	---

MAIN STRENGTHS



ISC® with extended mode selector

Intelligent Slicing Control (JAC patent) is an automatic pressure and slicing speed control system. It adapts the cutting action according to the consistency of the bread. No manual setting needed. The ISC® with extended mode selector provides two extra automatic modes, to adapt to extreme cutting condition of very fresh breads or the need for particularly fast cutting rate.



ETL Sanitation Listed and ETL Listed US & Canada

The ETL Sanitation mark is awarded to food service equipment that has been rigorously tested against national sanitation requirements. This mark ensures you that the equipment is fit for use during food production as the manufacturer has not only passed the initial testing, but remains in compliance by completing periodic follow-up inspections. If the ETL Listed mark has a "US" to the bottom right, it has passed U.S. product safety standards. If it has a "C" to the bottom left, it has passed Canadian product safety standards. If the ETL mark displays both identifiers, it meets both standards.



Plug configuration

NEMA 5-15P



Partners

JAC is a member of these different associations



Rear safety cover

Closing it initiates the slicing process and it opens automatically when slicing is complete. Not available with the AutoMode option.