

HG24 Donut Glazers

Belshaw's HG24EZ and HG24C glazers allow fast, uniform glazing of donuts, cinnamon rolls and other baked goods. These glazers conveniently glaze one full 23" x 23" screen at a time with minimal waste.

Glazers are movable on casters and require little space. A bottom shelf provides storage space for screens and a glaze bucket. A drain tray is included to allow donuts to drain excess glaze for as long as needed. A drain valve allows left over glaze to be poured out back into a glaze bucket. Stainless steel construction and sound design facilitate cleaning and provide a durable product that will stand up to years of everyday use.

The EZlift method employed by the HG24EZ glazer eliminates the heavy lifting associated with standard hand glazers. Rather than being carried by the operator, the glaze applicator slides along rails, and tilts down to fill up with glaze. This design provides even glaze coverage with little strain on the operator.

STANDARD ITEM NUMBERS

- **HG24C** Item # 22534
- **HG24EZ** Item # 22536

STANDARD FEATURES

- Glazes a 24" x 24" screen of donuts (up to 3 dozen at once)
- **HG24EZ** glaze applicator slides on rails. Operator does not lift the glaze applicator manually.
- **HG24C** glaze applicator is a clamshell opening design to control flow of glaze. Operator lifts the glaze applicator manually.
- Drain tray is standard on both models
- Drain returns unused glaze to a bucket for later use.
- Stainless steel construction throughout
- 4" heavy duty water-resistant casters (2 lockable)
- Washable in rack washer or by hose down with brush
- Certified to NSF-2



HG24C Donut Glazer *Glazing screens supplied separately



HG24EZ Donut Glazer with EZLift *Glazing screens supplied separately)

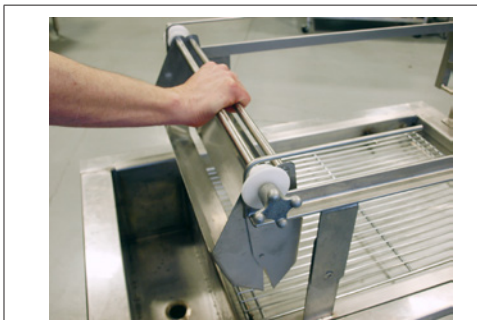

HG24EZ EZLift glaze applicator (slides on rails)



HG24C Clamshell glaze applicator (handheld)



HG24EZ EZLift operation

DIMENSIONS & SHIPPING DATA

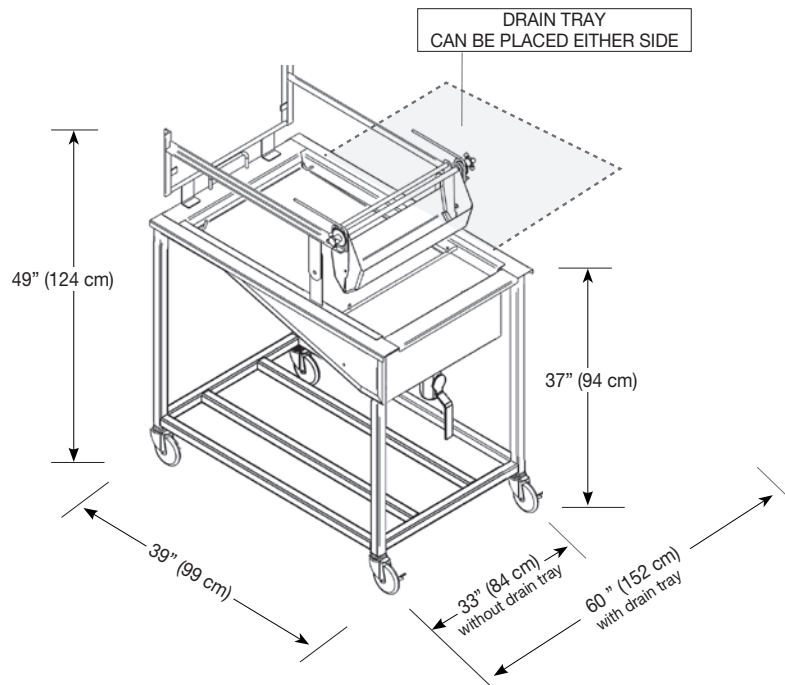

DIMENSIONS		HG24C Manual	HG24EZ EZLift
OVERALL DIMENSIONS 1 drain tray down	inches	33" W x 39" D x 37" H	33" W x 39" D x 49" H
	cm	84 x 99 x 94 cm	84 x 99 x 124 cm
OVERALL DIMENSIONS 2 drain tray extended	inches	60" W x 39" D x 37" H	60" W x 39" D x 49" H
	cm	152 x 99 x 94 cm	152 x 99 x 124 cm
SHIPPING DATA (Approximate, shipped in carton or pallet)	inches	48"W x 40"D x 47"H	48"W x 40"D x 47"H
	cm	122 x 102 x 119cm	122 x 102 x 119 cm
	lbs	215 lbs	183 lbs
	kg	97 kg	83 kg
FREIGHT CLASS		250	250

GLAZING SCREENS (Purchased separately)

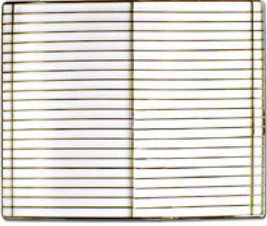
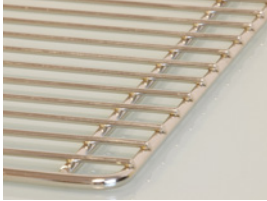
					APPROX. SHIPPING WEIGHT (Carton of 12 screens) 54 lbs (23 kg)
		GLAZER MODEL HG24C, HG24EZ	PART NUMBER (for GLAZING SCREENS) HG24-0001	SCREEN SIZE 24" x 24" (61 x 61 cm)	
HG24-0001 Glazing Screen (made with high quality nickel plated steel)		FREIGHT CLASS: 70 (Screens only)			