

# Industrial Line

Industrial machines

MADE IN ITALY

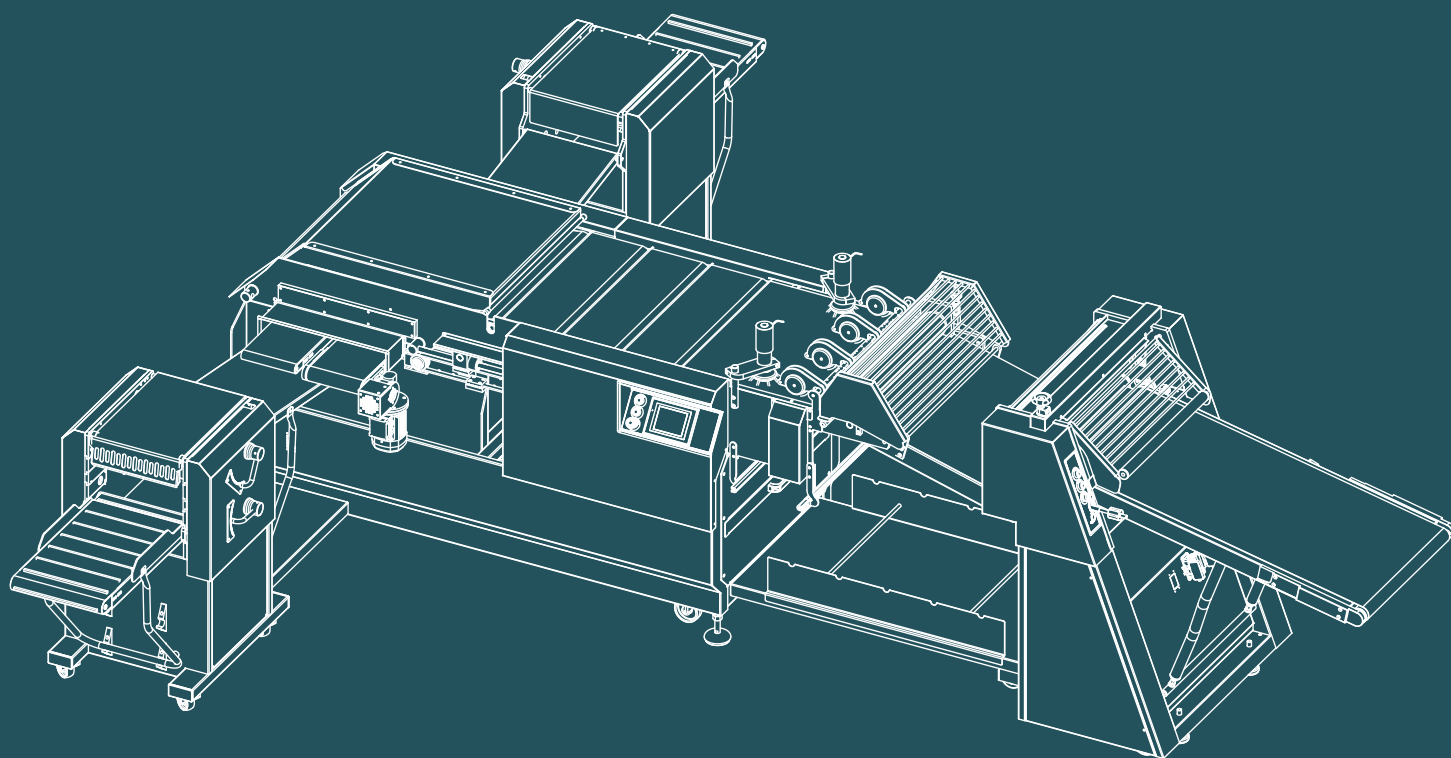

1982  
**40** Tekno  
2022 Stamap  
ANNIVERSARY [www.teknostamap.com](http://www.teknostamap.com)

Technology boosting creativity

# Make Up line

For every shape products

## PRODUCTION LINES FOR ALL TASTES

Calibrator with automatic flour duster

Cutting station with rollers

Humidifier

Folding unit

Electric or pneumatic guillotine with the possibility of been positioned anywhere on the table

Device for trims collection

Panning unit with touch screen panel

Pneumatic volumetric dosing machine with valves for suction control and product dosage

Images only have a demonstration purpose, contact our dealer to have a customized offer

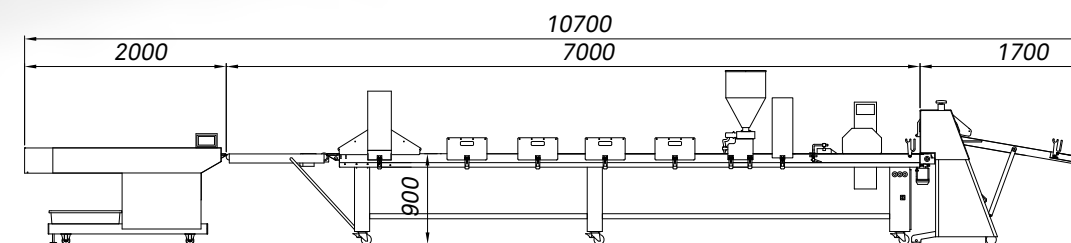

**Technical features**  
Make Up line

	U.M.	
Length according to customer info	mm	4000-5000-6000
Table height	mm	900
Belt width	mm	650
Belt speed	m/min	1-6
Engine power	Kw	0,37
Electrical supply	V	220/380
	HZ	50/60
Control supply	V DC	24
Max speed guillotine	Tagli/mm	100

Tekno Stamp reserves to make technical changes in any moment and without notice



The new lines allow the production of an extremely wide range of product shapes.



Electric dosing machine for homogenized and creamy products



Optional: Electrical panning with pan movement for double discharge products. Programmable speed and product discharge

# Tekno Stamap

Via Tretti Marotti, 8  
36040 Grisignano di Zocco  
Vicenza \_ Italy

T. +39 0444 - 414 735  
F. +39 0444 414 719

[www.teknostamap.com](http://www.teknostamap.com)  
[info@teknostamap.com](mailto:info@teknostamap.com)