

Industrial Line

Industrial machines

MADE IN ITALY

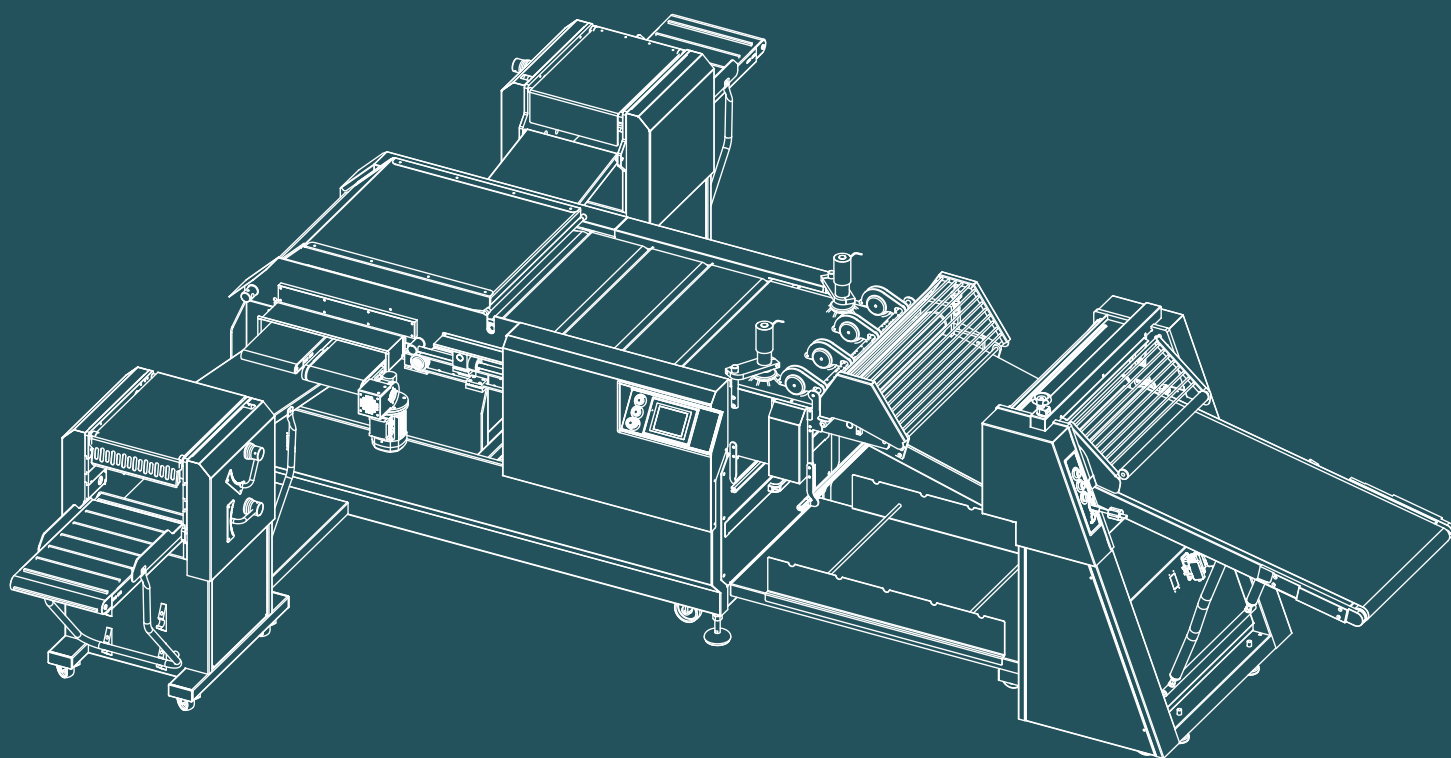

1982
40 Tekno
2022 Stamap
ANNIVERSARY www.teknostamap.com

Technology boosting creativity

EN

Tables T series

Production of croissant, pain au chocolat, mini strudel and puff pastry products

The T series tables are developed on the needs of small and medium-sized workshops, which need a simple and effective tool to speed up the production of croissants, pain au chocolat, mini strudel and puff pastry products generally. Thanks to the input calibrator, available as an option, the

maximum precision of the sheet thickness is ensured to maintain a standard weight piece after piece. Thanks to the customization of any component of the table, each customer can get maximum efficiency for his own laboratory.

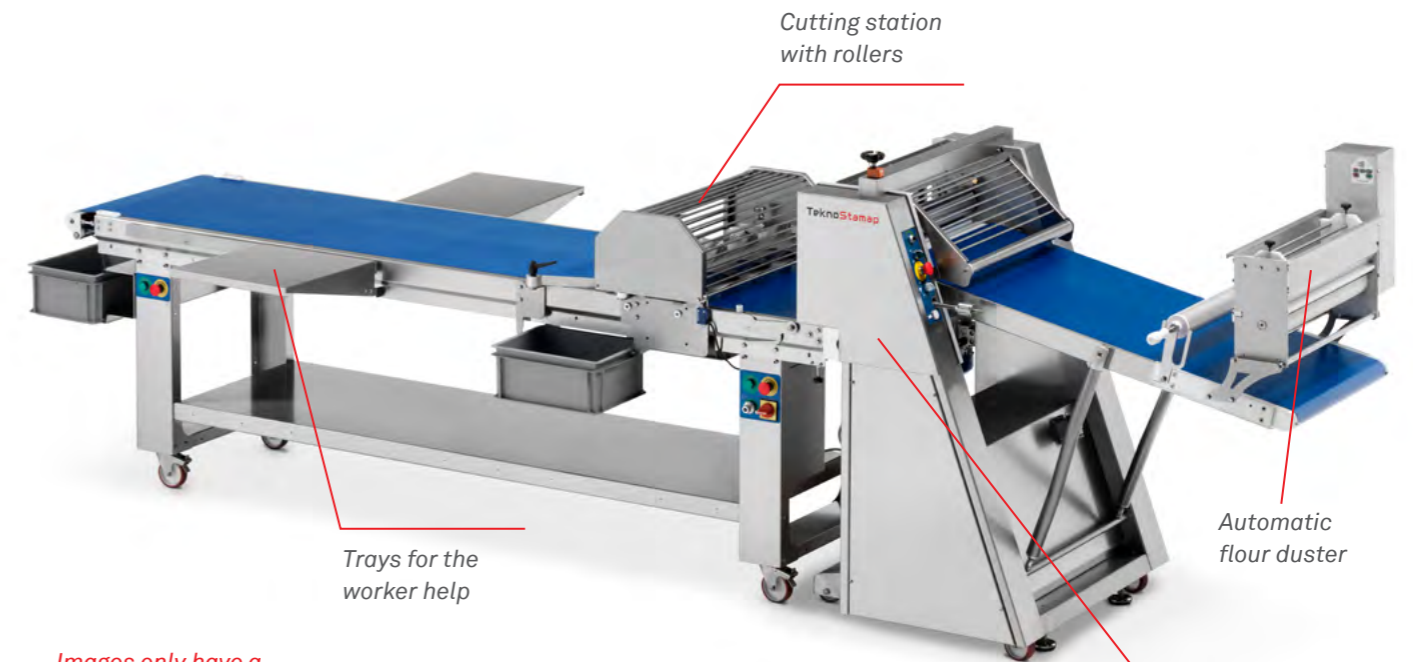

Images only have a demonstration purpose, contact our dealer to have a customized offer

Optional: input calibrator



**Technical sheet
Tables T series**

U.M.

Table length	mm	2000/3000/4000/5000/6000
Belt length	mm	650
Electrical absorption	Kw	0,25
Voltage	V	220/380

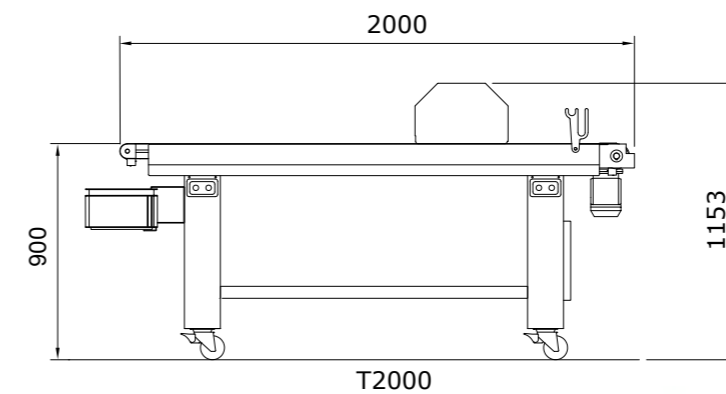

Ideal for manual filling or wrapping of puff pastry products.

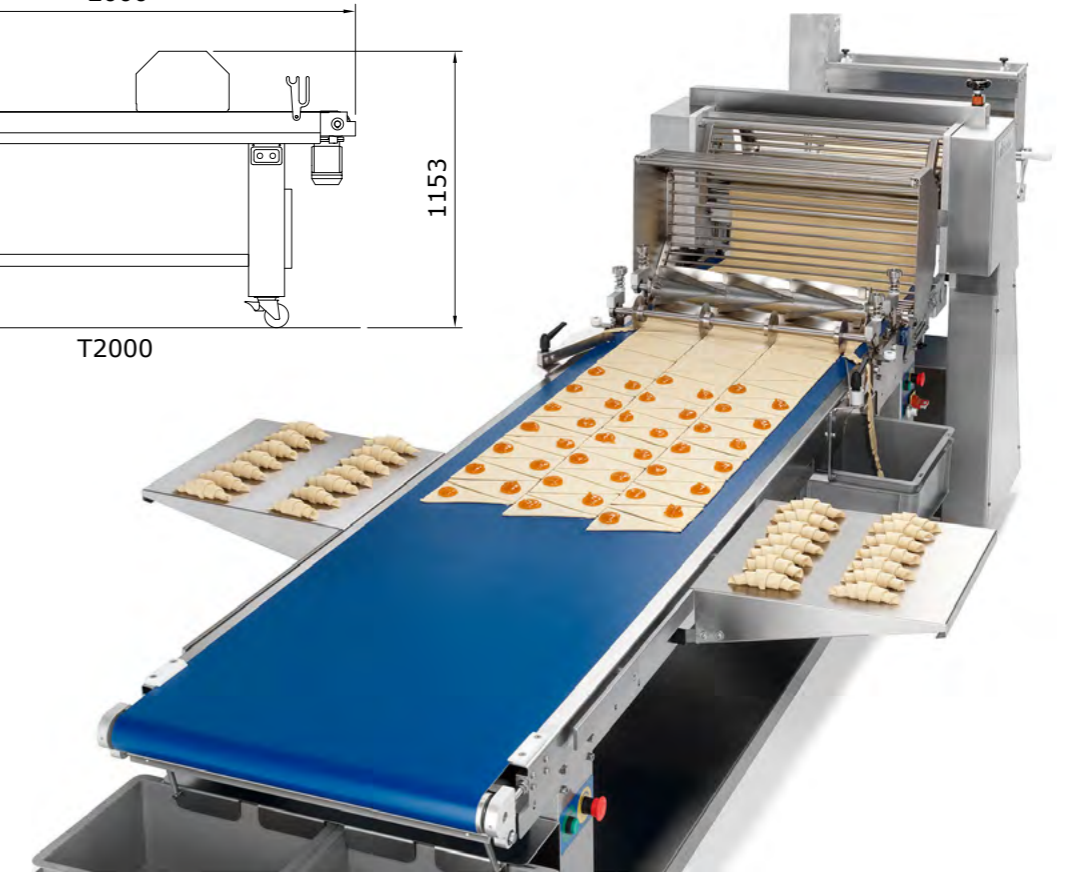

Tekno Stamap

Via Tretti Marotti, 8
36040 Grisignano di Zocco
Vicenza _ Italy

T. +39 0444 - 414 735
F. +39 0444 414 719

www.teknostamap.com
info@teknostamap.com